



PROPERTIES

DESIGN

Clamping collar with clamping screw. Clamping hub with concave driving jaws and clamping screw. Backlash free, vibration damping, electrically isolating elastomer insert press fit into the jaw sets. Clutch system: spring loaded ball-detent principle, in a special compact, low inertia design.

AVAILABLE FUNCTION SYSTEMS

- ▶ W = Single position / automatic re-engagement (standard)
- ▶ D = Multi-position / automatic re-engagement

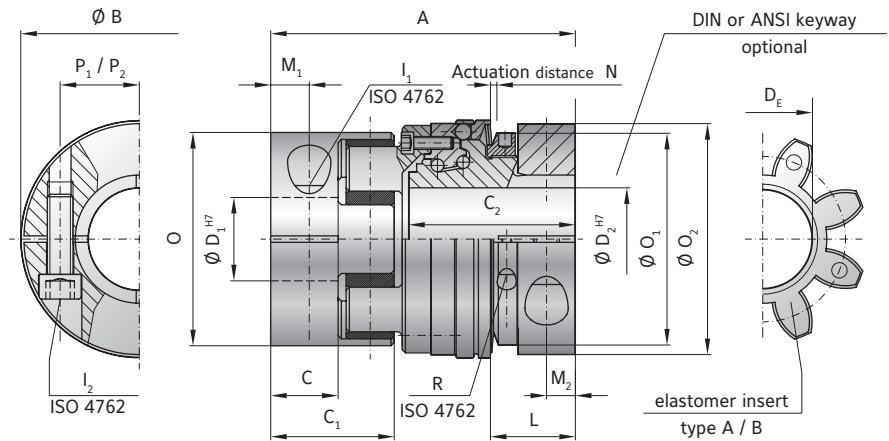

MODEL SLE

SIZE		30		60		150		300	
Type (elastomer insert)		A	B	A	B	A	B	A	B
Rated torque	T_{KN}	60	75	160	200	325	405	530	660
Max. torque	$T_{KN max}$	120	150	320	400	650	810	1060	1350
Adjustment range* possible from -to	(Nm) T_{KN}	10-35 30-80 40-135		30-80 60-120 100-200		40-100 100-200 150-300		200-350 300-450 400-550 550-700	
Overall length	(mm) A	85		93		122		135	
Actuation ring diameter	(mm) B	63		74		92		118	
Hub length (coupling hub end)	(mm) C/C ₁	20 / 36		21 / 39		31 / 52		34 / 57	
Length of hub (torque limiting portion)	(mm) C ₂	45		53		63		72	
Bore diameter from Ø to Ø H7	(mm) D ₁ /D ₂	12-32 / 12-30		16-36 / 16-35		19-45 / 19-42		22-60 / 22-60	
Inner diameter (elastomer insert)	(mm) D _E	26.2		29.2		36.2		46.2	
ISO 4762 screw, coupling side / torque limiter side		M6		M8		M10		M12	
Tightening torque	(Nm) I ₁ /I ₂	15		40		75		130	
Distance to actuation ring edge	(mm) L	22		26		32		35	
Distance	(mm) M ₁ /M ₂	10 / 7.5		12 / 9		15 / 11		17.5 / 12	
Actuation distance	(mm) N	1.3		1.5		1.8		2	
Clamping hub Ø, elastomer coupling	(mm) O	56		66.5		82		102	
Ø Adjustment nut	(mm) O ₁	55		66		82		100	
Clamping hub Ø, safety coupling	(mm) O ₂	59		72		90		112	
Distance to clamping screw, coupling side / torque limiter side	(mm) P ₁ /P ₂	21 / 21.5		24 / 25		29 / 33		38 / 41	
Adjustment nut's clamp screw ISO 4762		M3		M3		M3		M4	
Tightening torque	(Nm) R	2		2		2		4.5	
Approx. weight	(kg)	0.4		0.8		1.5		2.9	
Approx. moment of inertia at D max. (10 ⁻³ Kg·m ²)	J _{ges}	0.3		1		1.8		5	
Static torsional rigidity	(Nm/rad)	3290	9750	4970	10600	12400	18000	15100	27000
Dynamic torsional rigidity	(Nm/rad)	7940	11900	13400	29300	23700	40400	55400	81200
Lateral ±	approx. (mm)	0.12	0.1	0.15	0.12	0.18	0.14	0.2	0.18