

Data Sheet
ROTAX® Rxhq 110-50T1.5

Edition 24. June 2024

Hollow Shaft Motor
ROTAX® Rxhq = high torque

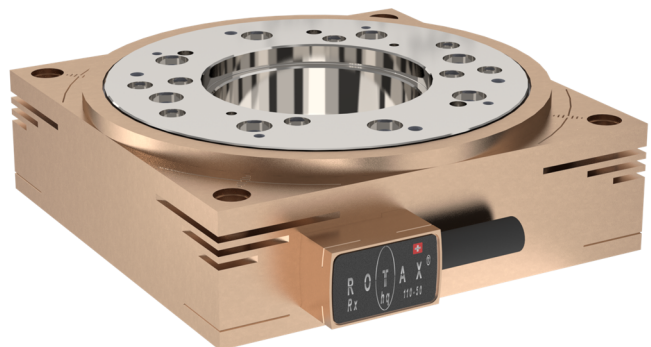

Highlights

- Compact direct drive with high torque
up to 4.0Nm (35.40 lbf·in)
- Flexible positioning with a repeatability
of ± 1 arcsec
- Single-turn absolute encoder
- Large hollow shaft with a diameter
of 50mm (1.97")
- No wear and tear, the direct drive ensures
maximum precision over the entire service life
- Variable one-cable connection to XENAX® in
180° grid orientation
- Torque limitation and torque monitoring with
XENAX® servo controller

General

The direct drive developed in-house impresses with its flat design, compact external dimensions and a hollow shaft with a diameter of 50mm. Cables, vacuum or compressed air lines, light and laser beams, glass fibers or camera lenses can thus be easily guided through the hollow shaft.

The absolute measuring system allows an immediate start without previous referencing.

With a resolution of 120'000, 648'000 or 2'592'000inc. per revolution, repeatability of ± 1 arcsec can be achieved. The single-cable connection can be supplied in right-hand or left-hand output configuration.

Together with the patented "Force Calibration" function, undesired cogging, weight and friction forces of the ROTAX® Rxhq direct drives can be easily compensated. This makes it possible to specify, limit and monitor torques in processes. Together with the Forceteq® basic technology included in the XENAX® servo controller, complete torque/distance diagrams can be recorded - an additional torque sensor is not necessary.

Alois Jenny
Jenny Science AG

Inhaltsverzeichnis

1 Dimension ROTAX® Rxhq 110-50T1.5	4
1.1 Installation dimension	4
1.2 Hollow shaft	5
1.2.1 Front flange dimensions	5
1.2.2 Centering rings	6
1.2.3 Hole pattern for direct assembly	6
1.3 Installation options	7
1.3.1 Installation rear side with distance sleeves	7
1.3.2 Installation flange side with centering ring	8
2 Smart Praxis Oriented Details	9
2.1 Hollow shaft diameter 50mm (1.97")	9
2.2 Single-Turn Absolut Encoder	9
2.3 Torque limitation and torque measurement	9
2.4 One-Cable connection reduces cabling requirements	10
2.5 Cabel connection 180° pattern	10
3 Performance data	11
3.1 Techniscal specification	11
3.2 Torque/Speed curve	12
4 Accuracy	13
4.1 Positioning	13
4.2 Mechanical accuracy	13
5 Maintenance, Life time	14
5.1 Lubrication	14
5.2 Life time	14
6 Safety, Environment	15
6.1 Safety with XENAX® Servo Controller	15
6.1 Environmental Conditions	15
7 Note	16

1 Dimension ROTAX® Rxhq 110-50T1.5

1.1 Installation dimension

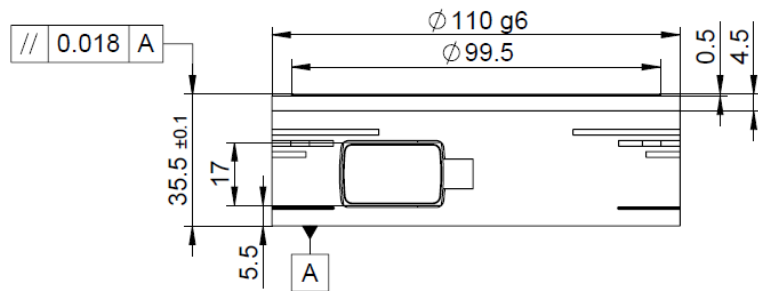

SCHNITT A-A
(1:1)

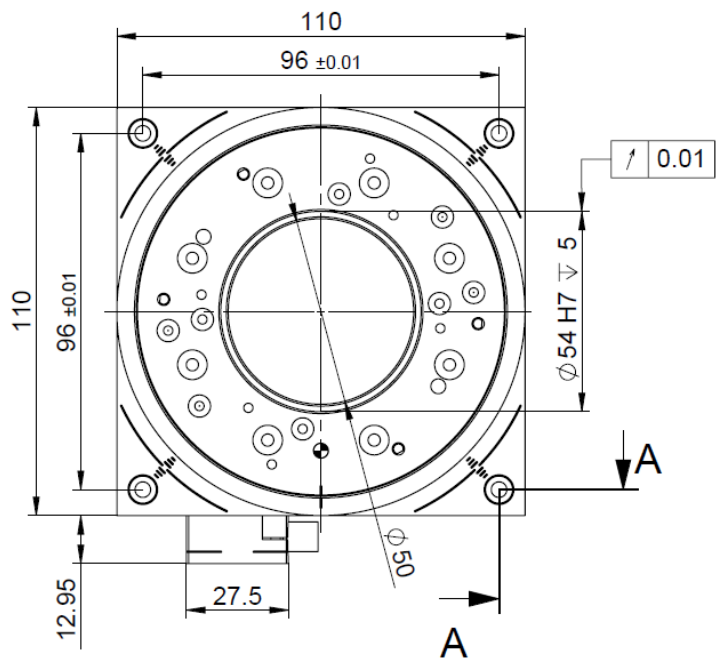
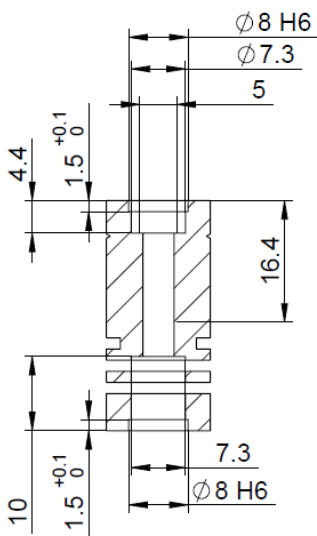

1.2 Hollow shaft

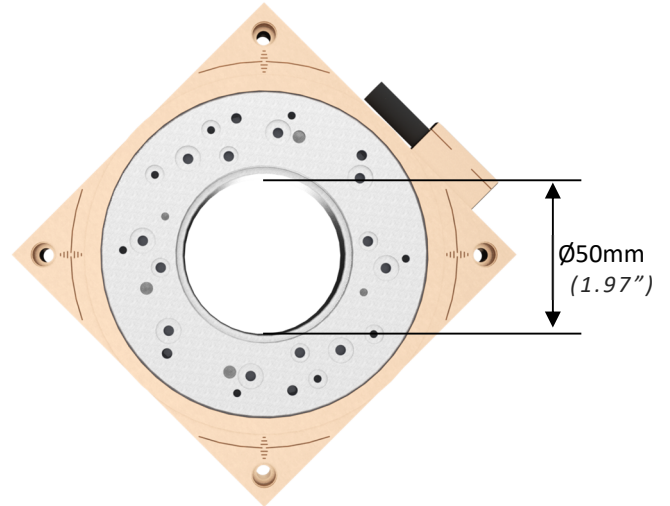

1.2.1 Front flange dimensions

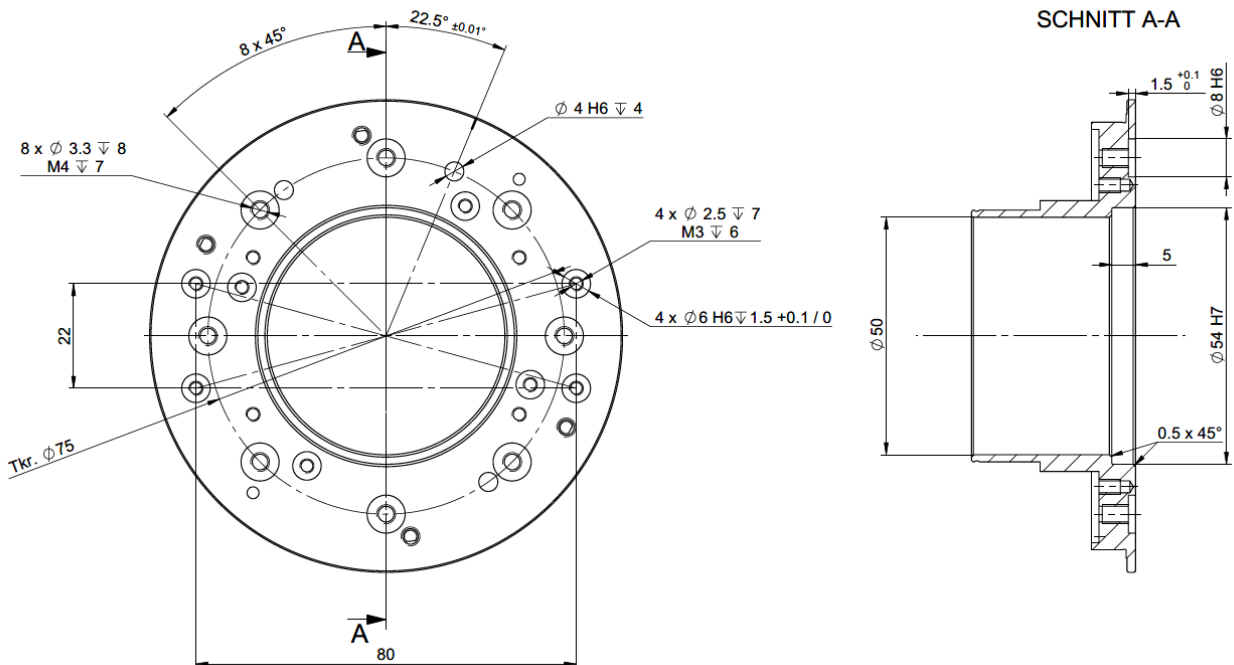

1.2.2 Centering rings

Centering rings for boreholes $\varnothing 8$ g6 x 1.5 in
Pitch circle diameter 75

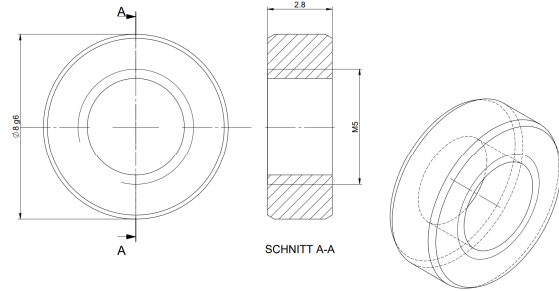

1.2.3 Hole pattern for direct assembly

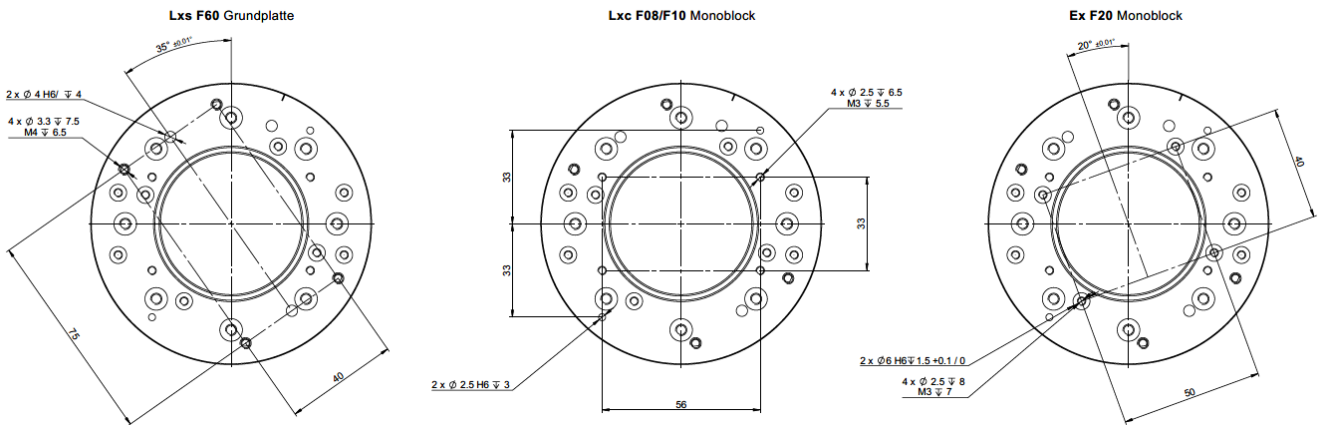

1.3 Installation options

1.3.1 Installation rear side with distance sleeves

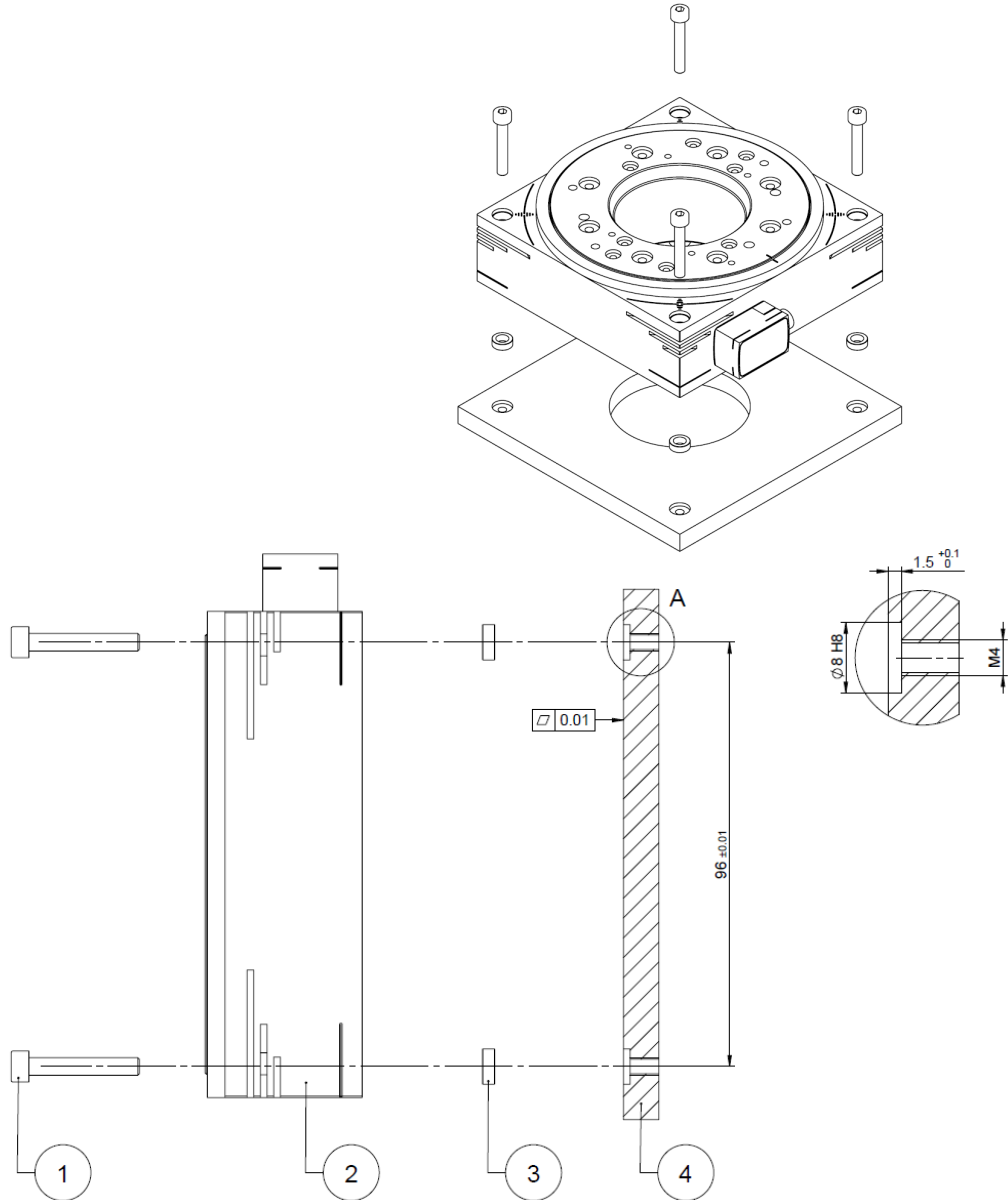

Pos.	QTY	Designation
1	4	Fixing screws M4 (max. tightening torque 2.9Nm (25lbf·in))
2	1	ROTAX® Rxhq 110-50T1.5
3	4	Centering rings (Ø8 g6 x 1.5)
4	1	Mounting plate customer

1.3.2 Installation flange side with centering ring

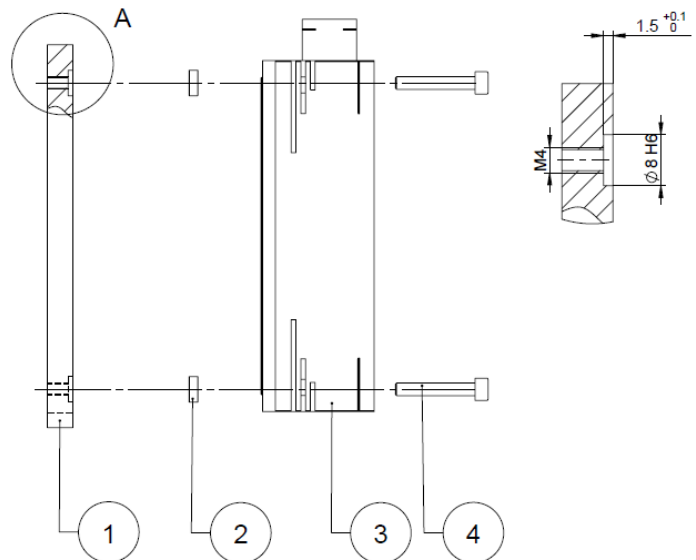
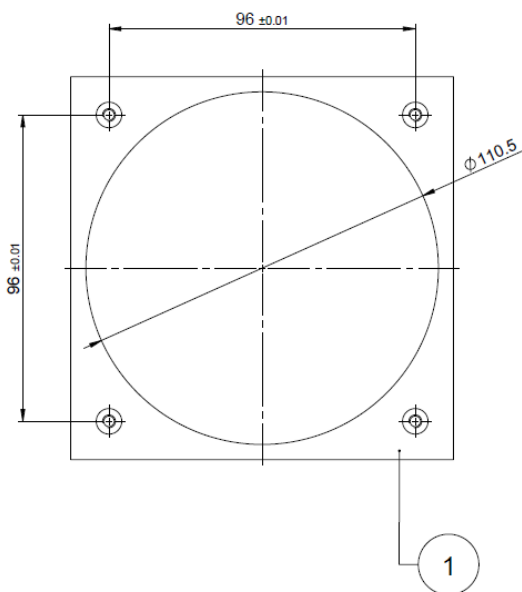
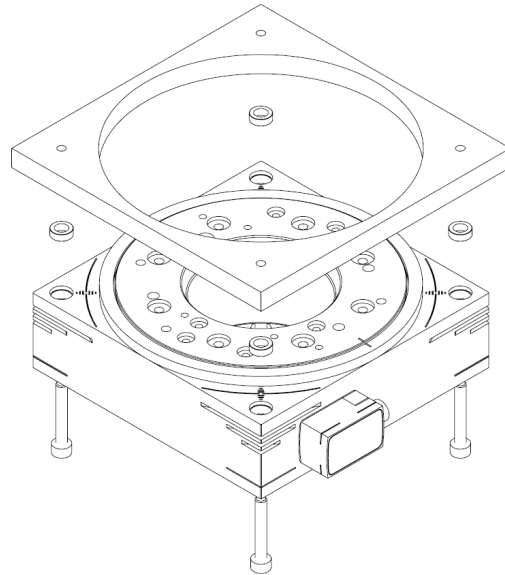

Pos.	QTY	Designation
1	1	Mounting plate, customer – Flange side
2	4	Centering ring (Ø8 g6 x 1.5)
3	1	ROTAX® Rxhq 110-50T1.5
4	1	Fixing screws M4 (max. tightening torque 2.9Nm (25lbf·in))

2 Smart Praxis Oriented Details

2.1 Hollow shaft diameter 50mm (1.97")

The large hollow shaft with a diameter of 50mm (1.97") offers generous space for cables, vacuum or compressed air lines, light and laser beams, glass fibres and other media.

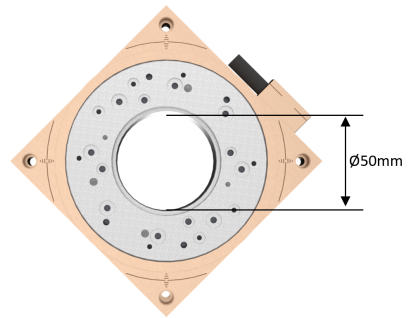

2.2 Single-Turn Absolut Encoder

Thanks to the integrated absolute encoder with a resolution of 120'000 inc. per revolution, repeatability of ± 11 arcsec can be achieved. The optical measuring systems with 648'000 inc. and 2'592'000 inc. then achieve ± 4 arcsec resp. ± 1 arcsec repeatability.

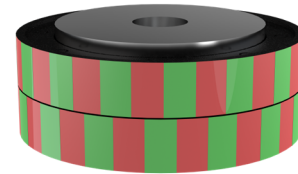

Due to the absolute position, the ROTAX® Rxhq is immediately ready for operation after power-on, no reference drive is necessary.

2.3 Torque limitation and torque measurement

The patented function „Force Calibration“ is able to compensate the magnetic cogging forces, the load and the friction forces of the Rotax® direct drive in a very simple way. This is how it becomes possible to limit and monitor torques in process. Together with the XENAX® servo controller, complete torque/displacement diagrams can also be recorded - an additional sensor is not necessary.

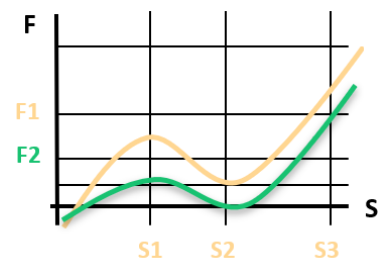

2.4 One-Cable connection reduces cabling requirements

The one-cable connection from Jenny Science simplifies the whole machine cabling complexity. In addition, the cable chains are more compact and lighter, need less room and achieve higher dynamics.

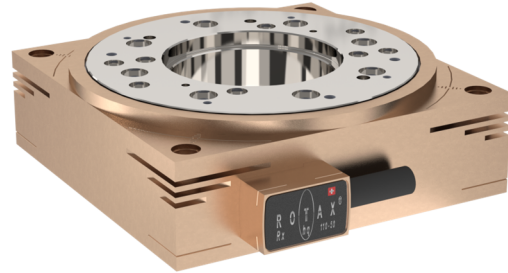

2.5 Cabel connection 180° pattern

The cable connection can be selected to the right, left and downwards. The corresponding article number must be specified when ordering. The cable outlet cannot be turned by yourself.

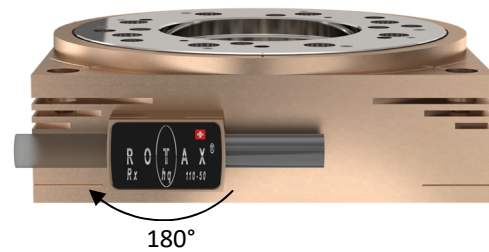

3 Performance data

3.1 Techniscal specification

Supply voltage				24V DC	48V DC
Nominal speed ⁽¹⁾ 120'000 Inc.	n_N	rpm		300	600
Nominal speed ⁽¹⁾ 648'000 Inc.	n_N	rpm		300	600
Nominal speed ⁽¹⁾ 2'592'000 Inc.	n_N	rpm		200	200
Stall torque	M_0	Nm (lbf·in)		1.6 (14.16)	1.6 (14.16)
Nominal torque ⁽¹⁾	M_N	Nm (lbf·in)		1.5 (13.28)	1.5 (13.28)
Peak torque ⁽²⁾	M_P	Nm (lbf·in)		4.0 (35.40)	4.0 (35.40)
Nominal current ⁽¹⁾	I_N	A		4.0	4.0
Peak current ⁽²⁾	I_P	A		12.0	12.0

Mechanical Data

Max. axial load		N (lbf)		10'000 (2248.0)
Max. moment load		Nm (lbf·in)		250 (2212.7)
Rotor moment of inertia	J_{Rot}	g·cm ² (lbf·in ²)		4'800 (1.6402)
Total weight	m	g (lbs)		1'200 (2.6500)

(1) continuous operation with 25C° (77°F) ambient temperature and convection cooling (ambient air)

(2) peak operation (duty 10%)

3.2 Torque/Speed curve



Supply voltage $U_s = 24\text{VDC}$ (120'000Inc. encoder)

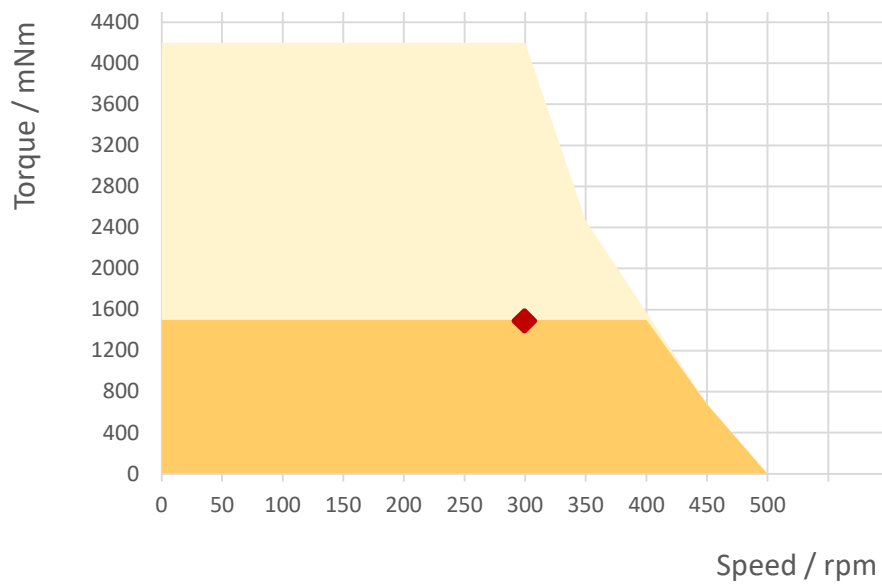

Supply voltage $U_s = 48\text{VDC}$ (120'000Inc. encoder)

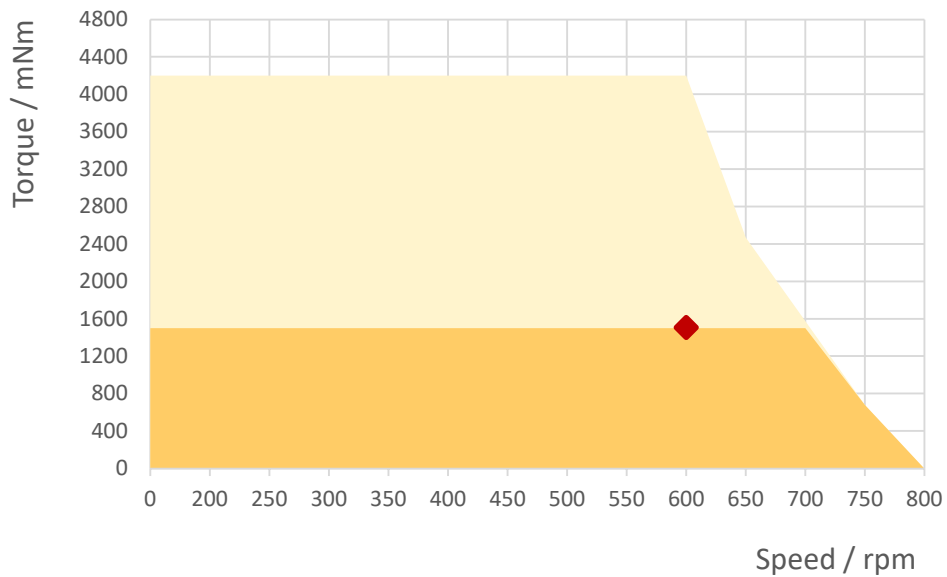

4 Accuracy

4.1 Positioning

Standard resolution polring Bi-directional repeatability	120`000 Inc., Vmax 600 rpm ± 11 arcsec
Optional optical resolution Bi-directional repeatability	648`000 Ink., Vmax 600 rpm ± 4 arcsec
Optional optical resolution Bi-directional repeatability	2`592`000 Ink., Vmax 200 rpm ± 1 arcsec

Reference drive

Zero point absolut

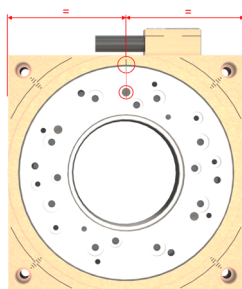

With the single-turn absolute encoder the position is available immediately after power-on. Therefore, no reference drive is necessary. For the alignment of the rotor flange, a single bore $\varnothing 4H6$ with aligned marking on the shaft and a marking on the symmetry axis of the housing is provided. The absolute zero point is in straight alignment of the two markings.

4.2 Mechanical accuracy

Runout [μm]

The ROTAX® Rxhq is delivered with the following tolerances as standard.
(Smaller tolerances are possible by selection individual motors from serial production i.E $< 5\mu\text{m}$)

Runout radial on $\varnothing 54H7$	$< 10\mu\text{m}$
Runout axial on $\varnothing 94$	$< 10\mu\text{m}$

5 Maintenance, Life time

5.1 Lubrication

The double row angular contact ball bearing of the ROTAX® Rxhq is maintenance-free and cannot be relubricated.

5.2 Life time

The ROTAX® Rxhq is a direct drive. This means no wear and tear and therefore highest precision over the whole lifetime.

Basically, the preloaded double row angular contact ball bearing is the life-determining element.

Actions with which life time can be extended:

- Trajectories with curve profiles instead of trapezoidal profiles (XENAX® Servo controller, default value S-curve profile = 20%).
- Dynamics not higher than needed.
- Completing non cycle time critical motions slower.
- Avoid pollution in the guides.

6 Safety, Environment

6.1 Safety with XENAX® Servo Controller

EN 61000-6-2:2005
Electromagnetic compatibility (EMC),
Immunity for industrial environments

EMC Immunity Testing, Industrial Class A

EN 61326-3-1
IFA:2012
EN 61326-1, EN 61800-3, EN 50370-1

Immunity for Functional Safety
Functional safety of power drive systems
Electrostatic discharges ESD, Electromagnetic Fields,
Fast electric transients Bursts, radio frequency common
mode

EN 61000-6-3:2001
Electromagnetic compatibility (EMC),
Emission standard for residential,
commercial and light-industrial
environments

EMC Emissions Testing, Residential Class B

EN 61326-1, EN61800-3, EN50370-1
IFA:2012

Radiated EM Field, Interference voltage
Functional safety of power drive systems

6.1 Environmental Conditions

Storage and transport	No outdoor storage. Storage rooms have to be well vented and dry. Storage temperature -25°C up to +55°C (-13°F up to 131°F).
Operational temperature	5°C - 50°C (41°F - 122°F) Environment, reduction in performance at 40°C (104°F).
Operational humidity	10-90% non-condensing.
Cooling	No need of external cooling. The mechanical mounting to a flange allows additional heat dissipation thanks to thermal conduction. This allows a higher performance.
Protection category	IP 40

7 Note

This data sheet contains copyright protected information. All rights are reserved. This document may not be in its entirety or partially copied, duplicated or translated without the prior consent of Jenny Science AG. Jenny Science AG grants no guarantee on, or will be held responsible for, any incidents resulting from false information.

Information in this instruction manual is subject to Modifications.

Jenny Science AG
Sandblatte 11
CH-6026 Rain, Schweiz

Tel +41 (0) 41 255 25 25

www.jennyscience.ch
info@jennyscience.ch

© Copyright Jenny Science AG 2024